

LOC		DIST		REVISIONS			
GP	00	REV	DATE	BY	CHK	APPV	
B	REVISED PER ECO-14-011808		12AUG2014	AP	SB		

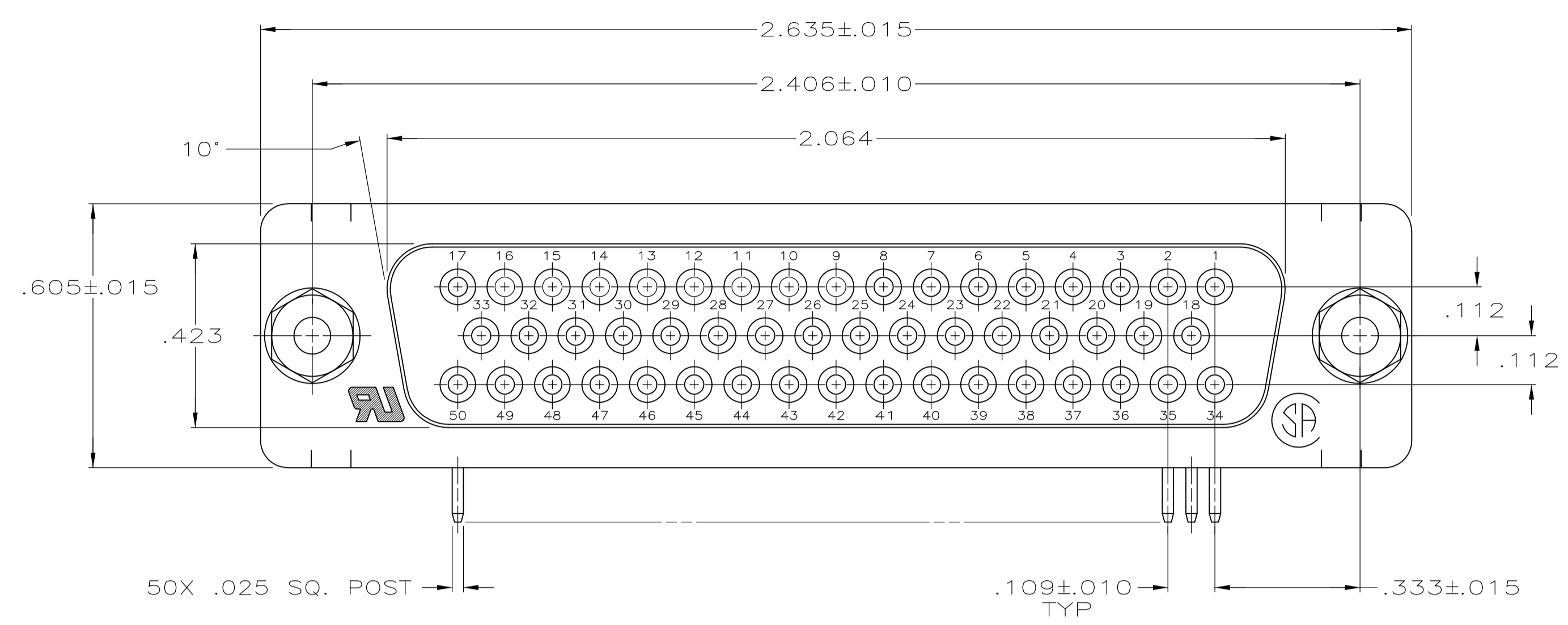

- 1 MOLDED PARTS: GLASS-FILLED PBT OR GLASS-FILLED NYLON, UL94V-0 RATED. COLOR: BLACK.  
SHELLS & BRACKETS: CARBON STEEL.  
CONTACTS: PHOS BRONZE  
SCREWLOCKS AND WASHERS: CARBON STEEL.
- 2 SHELLS: .000200 MIN TIN OVER .000100 MIN COPPER.  
BRACKETS: .000200 MIN TIN OVER .000050 MIN COPPER.  
SCREWLOCKS AND WASHERS: ZINC PLATED WITH CLEAR CHROMATE COATING.  
CONTACTS: SEE TABLE.
- 3 GOLD FLASH FOR A LENGTH OF .100 MINIMUM FROM MATING END, .000100 MINIMUM TIN ON OPPOSITE END, BOTH OVER .000050 MINIMUM NICKEL.
- 4 .000030 MINIMUM GOLD FOR A LENGTH OF .100 MIN FROM MATING END, .000100 MINIMUM TIN ON OPPOSITE END, BOTH OVER .000050 MIN NICKEL.  
-OR-  
GOLD FLASH OVER .000030 MINIMUM PALLADIUM NICKEL FOR A LENGTH OF .100 MIN FROM MATING END, .000100 MIN TIN ON OPPOSITE END, BOTH OVER .000050 MIN NICKEL.

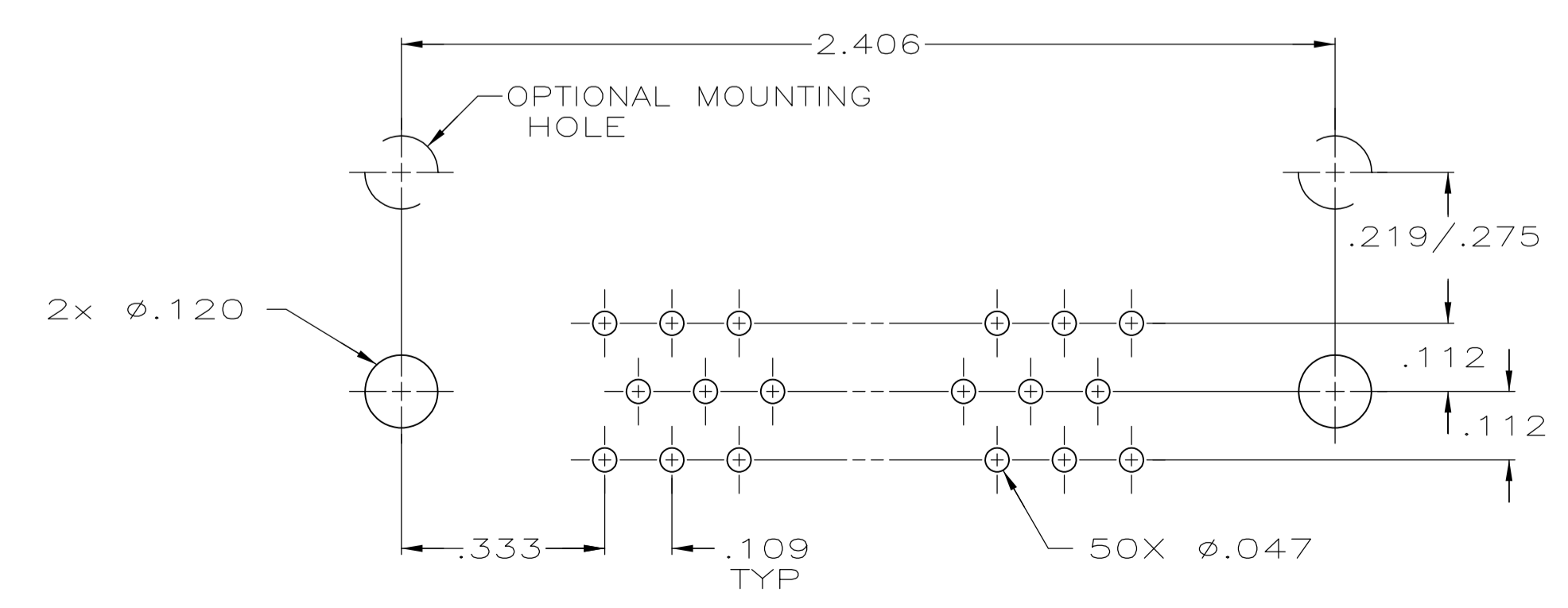
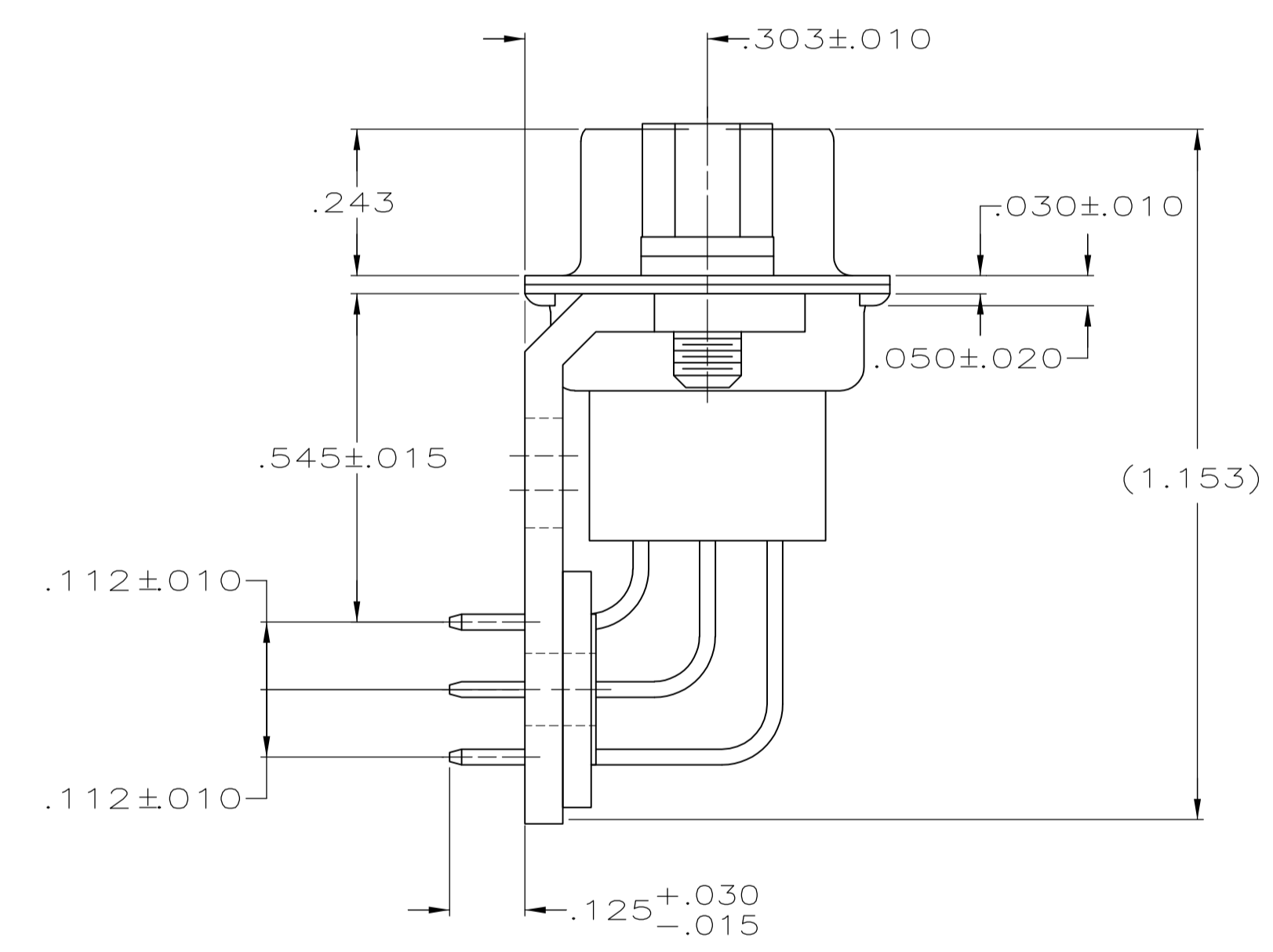
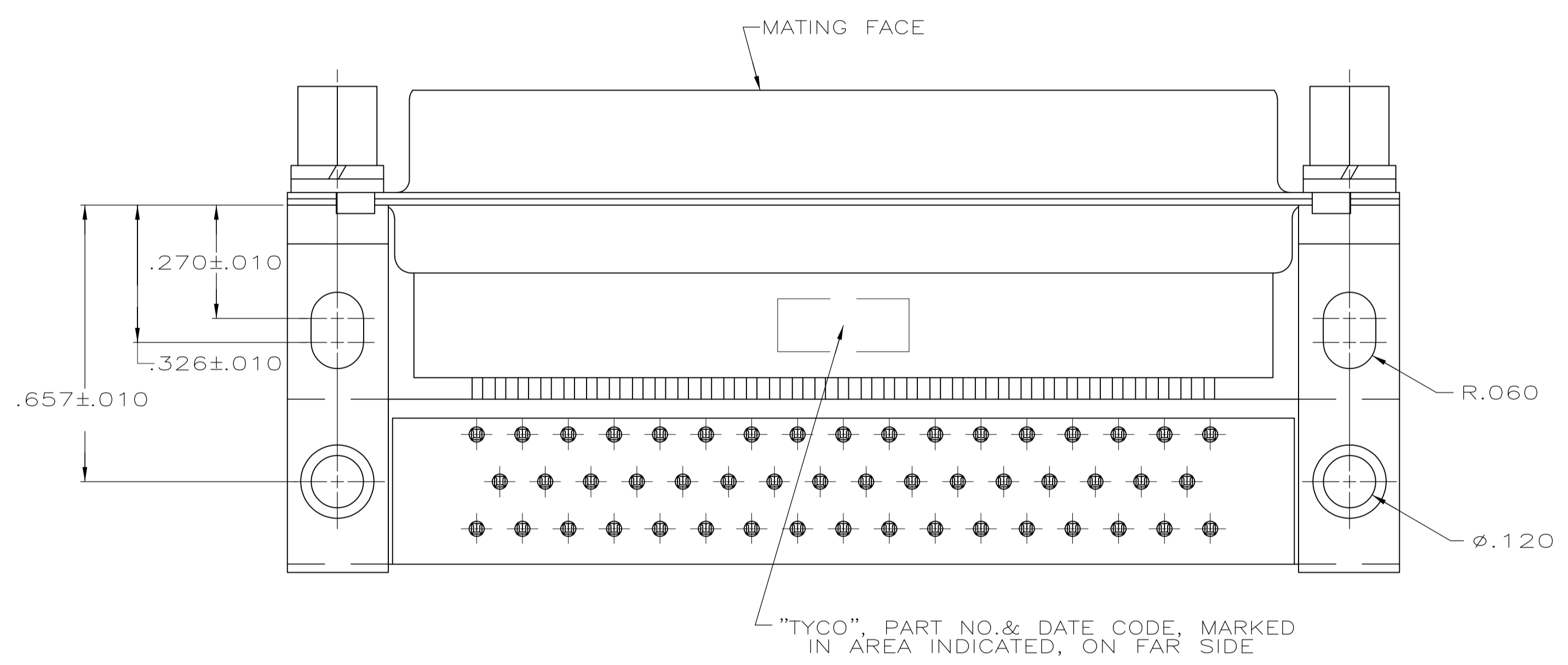

P.C. BOARD MOUNTING DIMENSIONS

4	5747193-2
3	5747193-1
CONTACT FINISH	PART NUMBER

THIS DRAWING IS A CONTROLLED DOCUMENT.		DIN 9-4-05		D. HENNY	
DIMENSIONS: INCHES		TOLERANCES UNLESS OTHERWISE SPECIFIED:		S. BOLASH 9-4-05	
0 PLC ± -		1 PLC ± -		M. WALMSLEY 9-4-05	
1 PLC ± -		2 PLC ± -		NAME	
2 PLC ± -		3 PLC ± .005		RECEPTACLE ASSEMBLY, SIZE 5, 50 POSITION, RIGHT ANGLE, .545 SERIES, .025 SQ. POSTS, WITH SCREWLOCKS, AMPLIMITE HDP	
3 PLC ± -		4 PLC ± -		PRODUCT SPEC	
4 PLC ± -		ANGLES ± °		108-40025	
MATERIAL		FINISH		APPLICATION SPEC	
1		2		114-40013	
CUSTOMER DRAWING		SCALE 4:1		SIZE CAGE CODE DRAWING NO RESTRICTED TO	
				A1 00779 C=5747193	
				WEIGHT	
				-	
				SHEET 1 OF 1	
				REV B	